

Trailer Mount

UpRight



- 43ft.4in. max. working height
- 19ft.4in. max. outreach
- Two person, 500lbs capacity platform
- 4ft.3in., 130° jib
- 90° powered platform rotation
- Hydraulic outriggers
- Compact dimensions and low towing weight

TL37

TL37 trailer mount specifications

TL37 TRAILER MOUNT

max. working height	43ft.4in.
max. platform height	36ft.9in.
max. outreach	19ft.4in.
platform capacity (SWL)	500lbs
outrigger footprint	11ft.10in. (A) x 9ft.10in. (B)
turret rotation	700°
platform rotation	90°
platform depth C	2ft.8in.
platform width D	3ft.11in.
stowed height E	6ft.5in.
towing length F	20ft.8in.
towing width G	4ft.10in.
weight (battery model)	3,064lbs*
control system	fully proportional hydraulic controls at platform and ground
power source	24V battery (4 x 6V 195ah batteries)
power options	bi-energy (gas & battery) power

*Machine towing weight depends on power configurations and supply of optional extras.

Specifications subject to change without notice. Photos and diagrams in the brochure are for promotional purposes only. Refer to appropriate UpRight operators manual for detailed instructions on the proper use and maintenance.

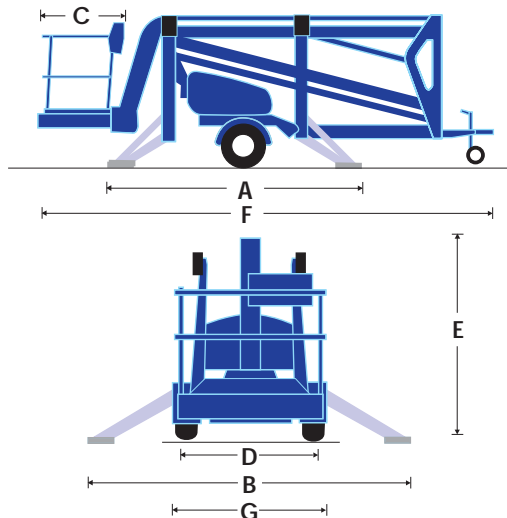

standard features

- 4ft.3in. jib with 130° working arc
- In-line boom design for maximum rigidity
- 20ft.8in. travel length
- 3,064lbs towing weight
- 90° hydraulically powered platform rotation
- Cycle protection guards
- Hand pump emergency lowering from platform
- Lock valves on all hydraulic cylinders
- Proportional live hydraulic controls
- Automatic reversing and overrun braking
- Integral road lighting board
- 24V battery (4 x 6V 195ah batteries)
- 1 year parts and labor warranty
- 5 year structural warranty

options

- Gas power
- Special paint colours

Other options available on request

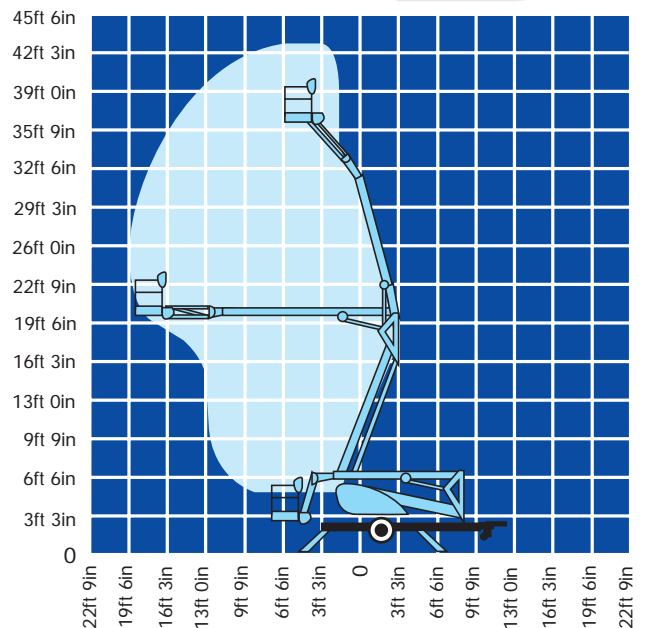

dimensions in ft. & in.

Meets or exceeds applicable requirements of OSHA, ANSI A92.2-2001 and CSA B354.1-04

CE This product is available with the CE mark confirming compliance with all relevant European Machinery Directives

manufactured by
UpRight

UpRight

2686 S. Maple Avenue, Fresno, CA 93725

Tel: +1 (866) 843-3350 (Toll Free) / +1 (559) 443-6600 • Fax: +1 (559) 268-2433

www.upright.com

BP2_TL37 USA 12/07